



SR-B 21



FX = flexible body, V = valve, HD = heavy duty, W = water cooled

Ordering no.	Type	Torch head			TSB 1025		TSB 3550				W
		Switch	Valve	F head	4 m 13 ft	8 m 26 ft	4 m 13 ft	8 m 26 ft	12 m 39 ft	16 m 52 ft	
0700025544	SR-B 21	X					X				X
0700025545	SR-B 21	X						X			X
0700025546	SR-B 21	X							X		X
0700025547	SR-B 21	X								X	X

SR-B 21

Item	Qty.	Ordering no.	Denomination	Notes
600	1	0700 025 613	Torch head rigid	
601	1	0700 025 620	Handle small	
602	1	0700 025 622	Precision switch dual	
	1	0700 025 605	Dual lever switch	
603	1	0700 025 638	Knuckle joint	Fits SR-B 21 and XCT-B 400W
604	1	0700 025 998	Rubber hose	25x1.5 mm, per m
605	1	0700 025 641	Hose coupling complete, large	
606	1	0700 025 999	Leather hose	0.6 m
607	3	0700 025 975	Hose clamp with ring	9.0 mm
608	1	0700 025 979	Control cable	per m
609	1	0700 025 994	Water hose	per m
610	1	314P10MI40	Power cable	4.0 m
610	1	314P10MI80	Power cable	8.0 m
610	1	314P16MI1C	Power cable	12.0 m
610	1	314P16MI1G	Power cable	16.0 m
611	2	0700 025 974	Hose clamp with ring	8.7 mm
612	1	0700 025 995	Gas hose	per m
613	1	0700 025 623	TIG connector 3550	
614	2	0365 803 010	Water quick coupling	
615	1	0700 025 634	Nut G1/8"	
616	1	0700 025 633	Nipple for G1/8"	
617	1	0700 300 584	2 pin plug	
	1	0700 300 585	5 pin plug	M12

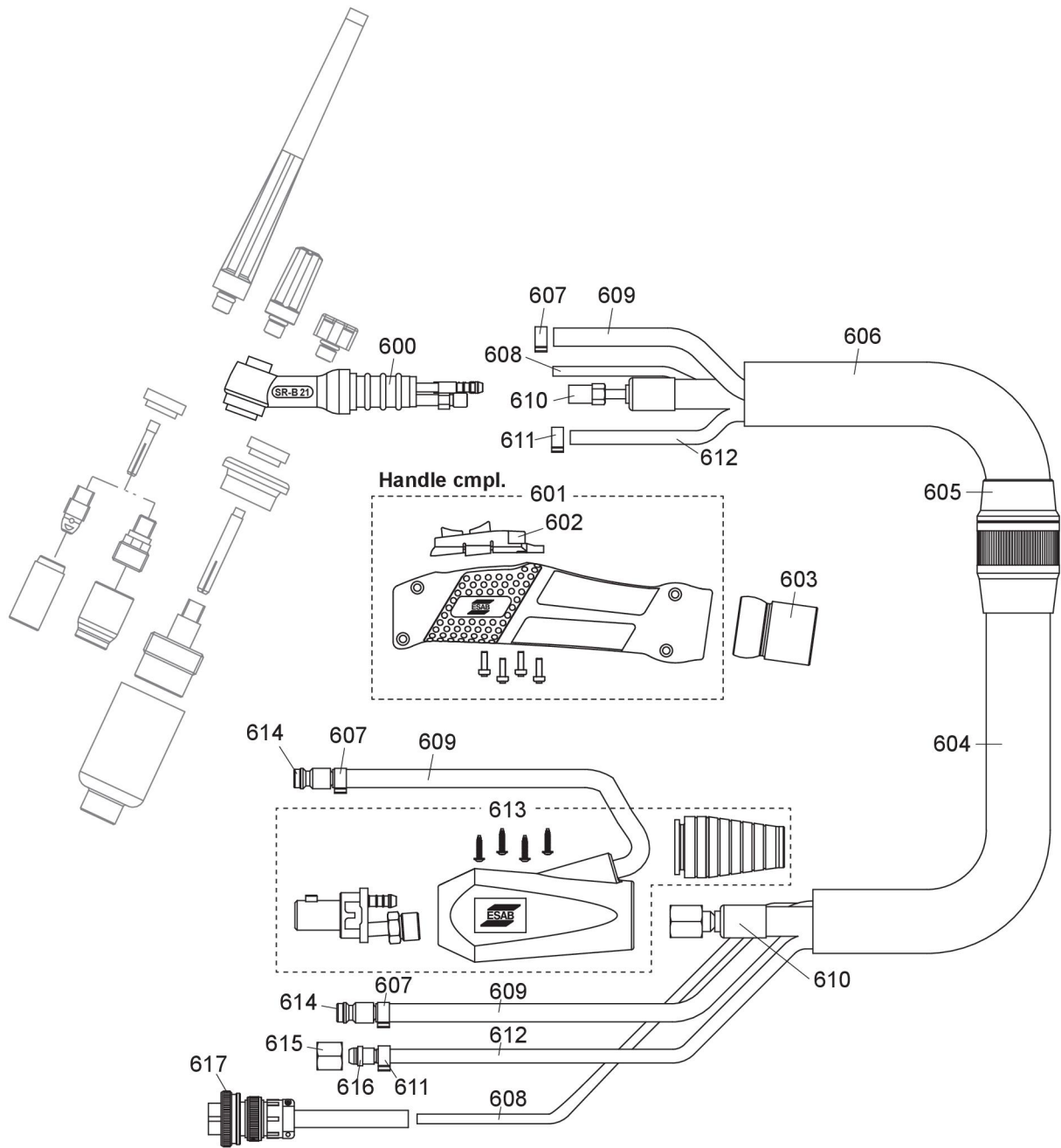

Bold = standard delivery

Item	Size	Description	Ordering no.
1	Long	Back cap	0365 310 051
	Medium		0365 310 050
	Short		0365 310 049
2		Heat shield	0366 960 017
3		Adaptor Jumbo gas lens	0157 123 026
4	Ø 0.5	Collet standard	0365 310 027
	Ø 1.0		0365 310 028
	Ø 1.6	Std. for SR-B 9	0365 310 029
	Ø 2.0		0700 025 662
	Ø 2.4	Std. for SR-B 20/21	0365 310 030
	Ø 3.0		0700 025 663
	Ø 3.2		0365 310 091
5	Ø 1.0	Collet body standard	0365 310 037
	Ø 1.6	Std. for SR-B 9	0365 310 038
	Ø 2.4	Std. for SR-B 20/21	0365 310 039
	Ø 3.2		0365 310 090
6	Ø 1.0	Collet body with gas lens	0157 121 016
	Ø 1.6		0157 121 017
	Ø 2.4		0157 121 018
	Ø 3.2		0157 121 041
7	Ø 6.4 (No. 4)	Gas nozzle standard	0365 310 044
	Ø 8.0 (No. 5)	L=30 mm	0365 310 045
	Ø 9.8 (No. 6)	Std. for SR-B 9	0365 310 046
	Ø 11.2 (No.7)	Std. for SR-B 20/21	0365 310 047
	Ø 12.7 (No. 8)		0365 310 048
	Ø 15.9 (No. 10)		0588 000 440
not illustrated	Ø 5.0 (No. 3)	Gas nozzle standard	0700 025 664
	Ø 6.4 (No. 4)	L=48 mm	0700 025 665
	Ø 8.0 (No. 5)		0700 025 666
	Ø 9.5 (No. 6)		0700 025 667
	Ø 6.5 (No. 4)	L=63 mm	0700 025 668
	Ø 8.0 (No. 5)		0700 025 669
	Ø 9.5 (No. 6)		0700 025 670
	Ø 6.5 (No. 4)	L=89 mm	0700 025 671
8	Ø 6.4 (No.4)	Gas nozzle for gas lens	0157 121 032
	Ø 8.0 (No.5)	L=25.5 mm	0157 121 033
	Ø 9.8 (No.6)		0157 121 034
	Ø 11.2 (No.7)		0157 121 039
	Ø 12.7 (No.8)		0157 121 040
	Ø 16.0 (No. 10)		0700 025 698

not illustrated	Ø 6.4 (No. 4)	Gas nozzle for gas lens	0700 025 658
	Ø 8.0 (No. 5)	L=35 mm	0700 025 659
	Ø 9.8 (No. 6)		0700 025 660
	Ø 11.2 (No.7)		0700 025 661
	Ø 16.0 (No. 10)		0700 025 699
9	Ø 1.0	Collet for Jumbo gas lens	0700 025 672
	Ø 1.6		0700 025 673
	Ø 2.4		0700 025 674
	Ø 3.2		0700 025 675
10	Ø 1.0-1.6	Gas lens, Jumbo	0700 025 676
	Ø 2.4		0700 025 677
	Ø 3.2		0700 025 678
11	Ø 9.8 (No. 6)	Gas nozzle for Jumbo gas lens	0157 123 088
	Ø 12.7 (No. 8)		0157 123 089
	Ø 15.9 (No. 10)	L=48 mm	0588 000 438
	Ø 19.0 (No. 12)		0157 123 098
	Ø 24.0		0588 000 437
	Ø 24.0	L=34 mm	0700 025 679

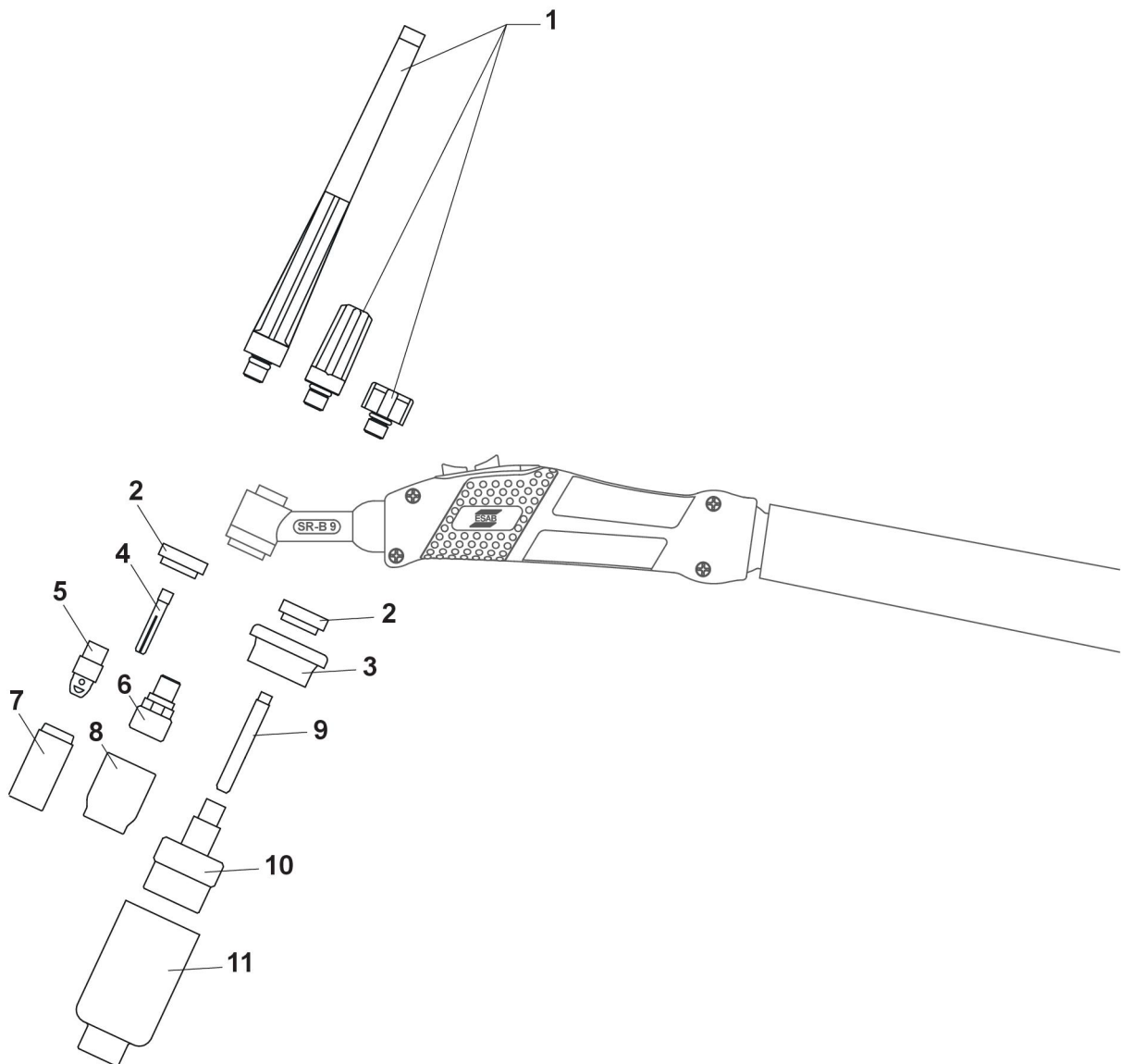

Tungsten electrodes Eco

Ordering no. 150 mm	Ordering no. 175 mm	Tungsten electrodes Eco	Diameter	Colour	Code	Current
-	0151 574 009	Wolfram, pure	Ø 1.6	Green	WP	AC
0151 574 245	-	Wolfram, pure	Ø 2.0	Green	WP	AC
0151 574 210	0151 574 010	Wolfram, pure	Ø 2.4	Green	WP	AC
0151 574 211	0151 574 011	Wolfram, pure	Ø 3.2	Green	WP	AC
-	0151 574 012	Wolfram, pure	Ø 4.0	Green	WP	AC
0151 574 237	0151 574 037	Cerium 2%	Ø 1.6	Grey	WC20	AC/DC
0151 574 242	-	Cerium 2%	Ø 2.0	Grey	WC20	AC/DC
0151 574 238	0151 574 038	Cerium 2%	Ø 2.4	Grey	WC20	AC/DC
0151 574 239	0151 574 039	Cerium 2%	Ø 3.2	Grey	WC20	AC/DC
0151 574 240	0151 574 040	Cerium 2%	Ø 4.0	Grey	WC20	AC/DC
0151 574 230	0151 574 050	Lanthanum 1.5%	Ø 1.0	Gold	WL15	AC/DC
0151 574 231	0151 574 051	Lanthanum 1.5%	Ø 1.6	Gold	WL15	AC/DC
0151 574 243	0151 574 246	Lanthanum 1.5%	Ø 2.0	Gold	WL15	AC/DC
0151 574 232	0151 574 052	Lanthanum 1.5%	Ø 2.4	Gold	WL15	AC/DC
0151 574 233	0151 574 053	Lanthanum 1.5%	Ø 3.2	Gold	WL15	AC/DC
0151 574 234	0151 574 054	Lanthanum 1.5%	Ø 4.0	Gold	WL15	AC/DC
0151 574 235	0151 574 055	Lanthanum 1.5%	Ø 4.8	Gold	WL15	AC/DC