

User : Annette Terney

Verification Unit cooler
31-03-2022

Inlet air temperature	[°C]	-20.0	Evaporating temperature	[°C]	-28.0
DT	[Δ°C]	8.0	Refrigerant *		CO2
Minimum number of units in room		0			
Heat exchanger	Aluminium fin		Casing		Standard
Fan motor feed	Standard		Type of fan motor		EC
Defrost	ED				
Selected model: * 1 x CGC 353A6			EC - ED		
Capacity	[kW]	11.57	Margin	[%]	0.0
DT	[Δ°C]	8.0	Tot. air flow	[m³/h]	7290.0

* Provide an appropriate defrosting system and number

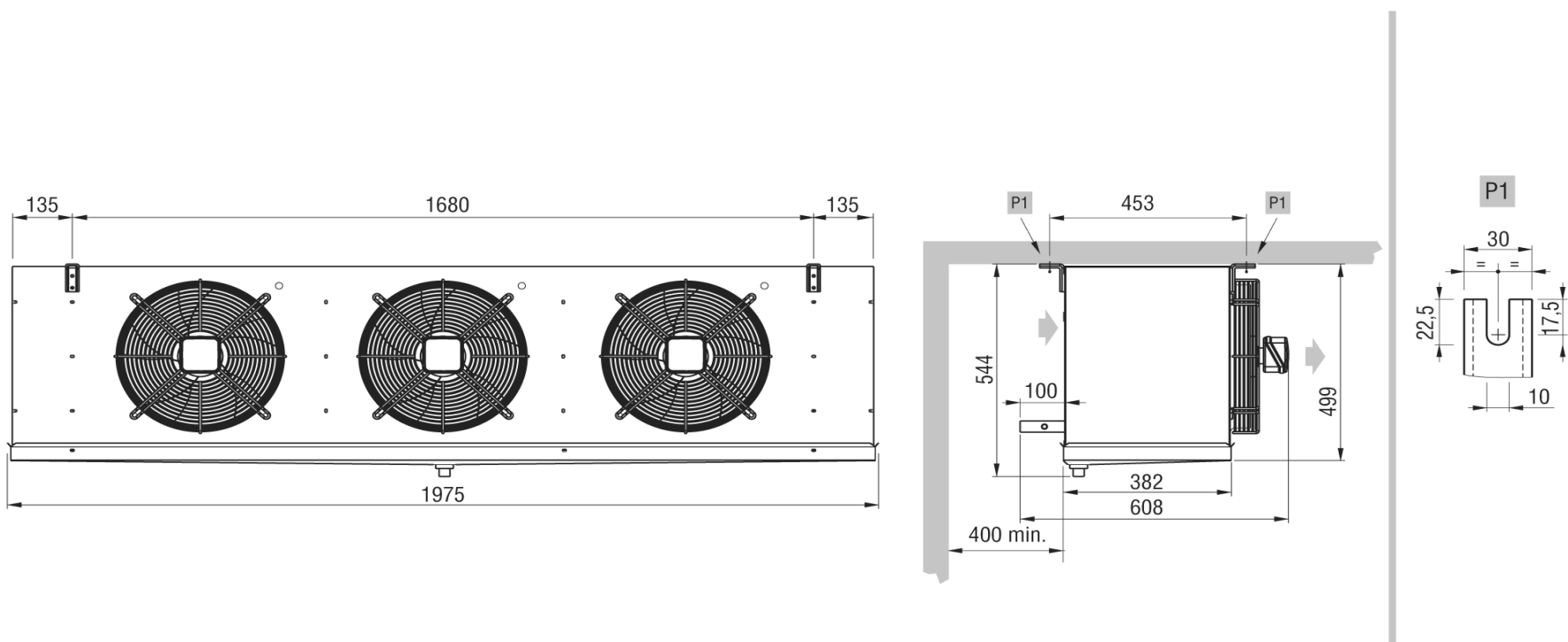

Weight	kg	67.000			
				[bar]	
Internal surface	m²	3.36	External surface	m²	47.40
Inlet connection		12.7 mm	Output connection		15.9 mm
Total circuit capacity	dm³	7.9	Fin spacing	mm	6
Drain connection		1" GAS			
Defrost		Electric		W	6300
Fan Motors	n.	3	Diameter	mm	350
Air flow	m³/h	7290	Air throw	m	18.0
Feed	V	230/1/50	Rotation speed	rpm	1450
Fan Motor	A	2.61	Absorbed power	W	450
Tot. Pres.S.Lev. 10 m.	dB(A)	50			



* The safety requirements for the use of refrigerants must comply with the provisions of the EN378 standards and the safety data sheets of each fluid used. The risk assessment for the use of A2L mid-flammable refrigerants shall be conducted by the user based on site requirements

EC fans: It is necessary to set these fans in order to get the required speed

EC - ED

Heat exchanger

Aluminium fin

Casing

Standard

Fan motor feed

Standard

Type of fan motor

EC - Electronically Commutated Motor

Defrost

ED - Electric



* The safety requirements for the use of refrigerants must comply with the provisions of the EN378 standards and the safety data sheets of each fluid used. The risk assessment for the use of A2L mid-flammable refrigerants shall be conducted by the user based on site requirements

EC fans: It is necessary to set these fans in order to get the required speed